

PHOENIX

Sealed-Combustion Gas-Fired Heat Transfer Mod/Com Water Heaters

Advanced Heating and Hot Water Systems



Certifications and Ratings:

The water heaters are UL/ULC listed and meet or exceed thermal efficiency and standby loss requirements of current ASHRAE standards. All water heaters are supplied with AGA/ASME rated temperature and pressure relief valve. The control panel is an integrated solid state temperature and ignition control device with integral diagnostics, LED fault display capability and a digital display of temperature settings. Meets all safety and construction requirements of ANSI Z21.10.3

CERTIFIED FOR A 150 PSI MAXIMUM WORKING PRESSURE.

Water Heaters Available in Traditional and Solar Models

100,000 BTU/Hr. thru 199,000 BTU/Hr.

Phoenix Gas-Fired Mod/Com Water Heaters are specifically designed to provide customers with maximum savings on operation, space and installation. Designed with the most advanced technology available, these products optimize efficiency and operating reliability.

Construction Features:

- 316L stainless steel tank construction (requires no anode rods).
- Load-Matching Modulating Burner
- No chimney required; direct vent using plastic pipe.
- Thermal efficiency of up to 97% dramatically reduces operating costs
- 85 equivalent feet of vent length.
- Low NO_x emissions. Meets SCAQMD Rule 1146.2
- High impact plastic jacket eliminates dents.
- 2" of non-CFC polyurethane foam insulation.
- Less than 1/2 degree per hour heat loss (R17).
- Corrosion-resistant, high efficiency 90/10 cupronickel heat exchanger.
- Self-diagnostic electronic control with digital readout for water temperature, set point and differential.
- Removable front cover allows easy access to burner assembly (24" service clearance recommended).
- Auxiliary connections for air handlers or radiant
- Temperature range from 70° to 160°
- Zero clearance to all combustible surfaces.
- Factory installed AGA/ASME rated T&P relief valve.
- Solar models equipped with additional heat exchanger

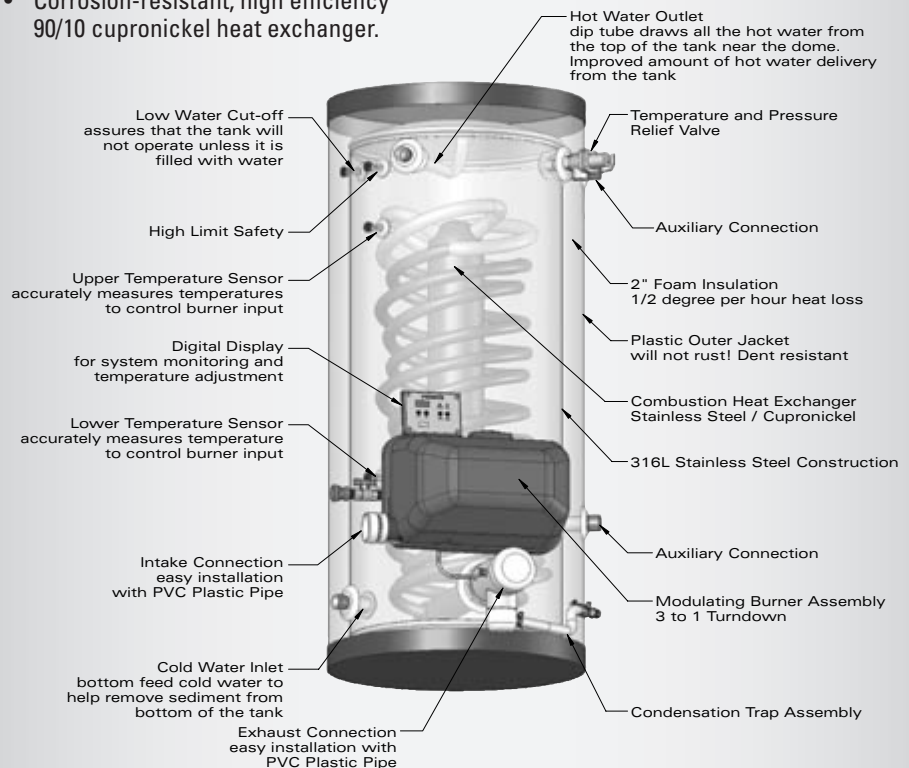

PHOENIX Dimensional Information

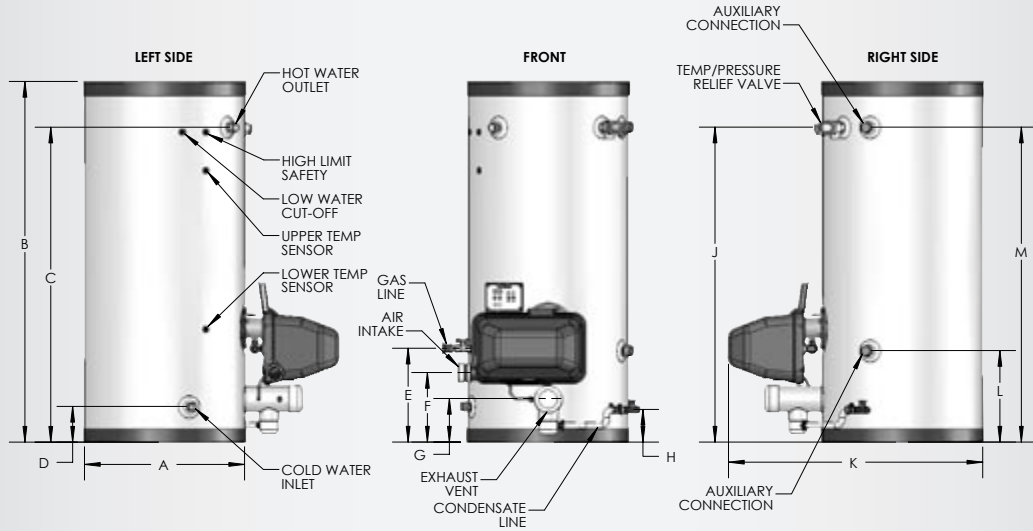

PHOENIX WATER HEATER DIMENSIONS													
MODEL #	GALLONS	A	B	C	D	E	F	G	H	J	K	L	M
PH-55	55	23"	52"	45"	5"	13-1/4"	9-3/4"	6"	3-7/8"	44-3/4"	36"	13"	45"
PH-80	80	23"	72"	60"	5-3/4"	15-1/4"	11-3/4"	6"	5-7/8"	62-3/8"	36"	13"	64-1/2"
PH-119	119	27"	74"	65-3/4"	7-1/2"	17"	13-1/2"	10-1/8"	7-1/2"	66-1/2"	40"	14-1/4"	65-3/4"

ALL DIMENSIONS ARE APPROXIMATE

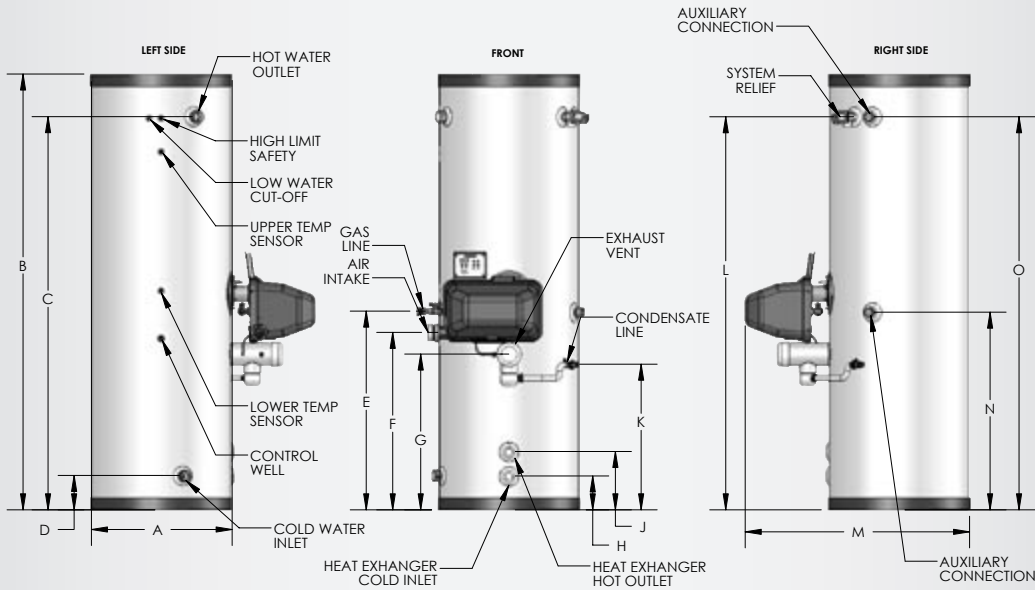

PHOENIX SOLAR WATER HEATER DIMENSIONS															
MODEL #	GALLONS	A	B	C	D	E	F	G	H	J	K	L	M	N	O
PH-80S	80	23"	72"	64"	5-1/4"	32"	29"	25-1/2"	5-3/4"	9-3/4"	27-3/4"	64"	36"	32"	64"
PH-119S	119	27"	74"	66"	7-1/4"	34"	31"	27-1/2"	7-1/2"	11-1/2"	25-3/4"	66"	40"	34"	66"

ALL DIMENSIONS ARE APPROXIMATE

PHOENIX SPECIFICATIONS								
MODEL #	GALLONS	BTU's	AIR INTAKE/ EXHAUST VENT SIZE	WATER INLET/ OUTLET SIZE	GAS LINE CONN.	SYSTEM RELIEF PIPE SIZE	SHIPPING WEIGHT	SHIPPING WEIGHT SOLAR
PH-55	55	100,000 & 130,000 199,000	2" 3"	1" NPT	3/4"	3/4"	175 LBS.	N/A
PH-80*	80	100,000 & 130,000 199,000	2" 3"	1-1/2" NPT	3/4"	3/4"	235 LBS.	245 LBS.
PH-119*	119	100,000 & 130,000 199,000	2" 3"	1-1/2" NPT	3/4"	3/4"	405 LBS.	415 LBS.

*For Solar Phoenix Only

PHOENIX Venting Options

SIDEWALL VENTING WITH TEE (INTAKE) AND COUPLING (EXHAUST)

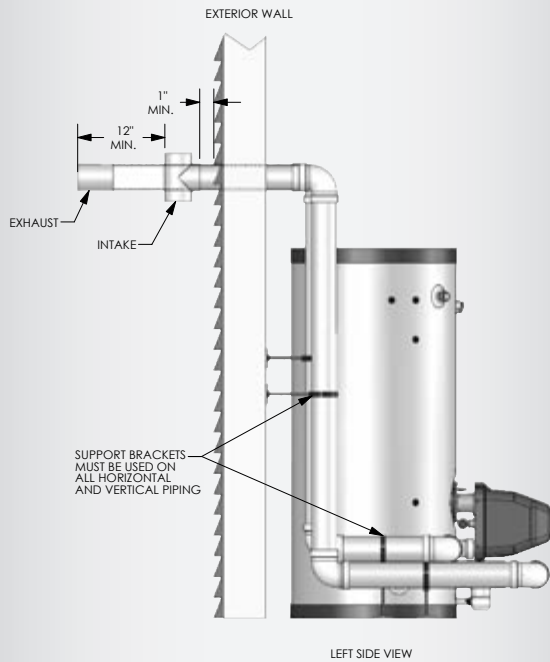

SIDEWALL VENTING WITH CONCENTRIC VENT KIT

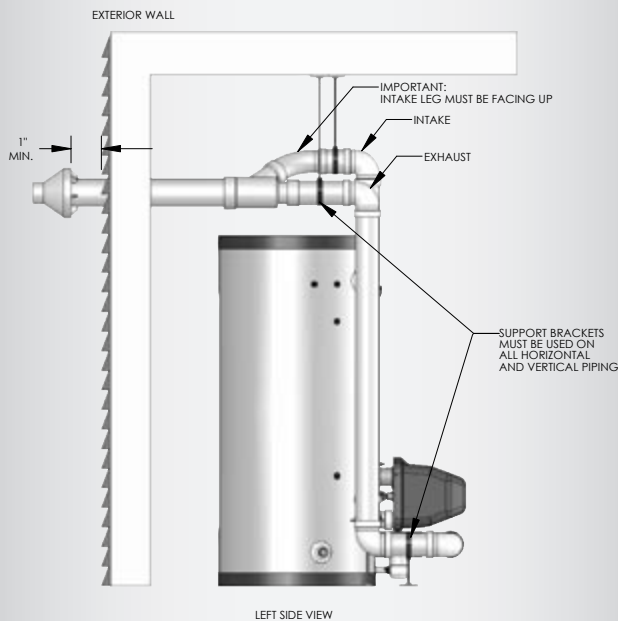

PHOENIX Piping Options

PHOENIX WITH AIR HANDLER

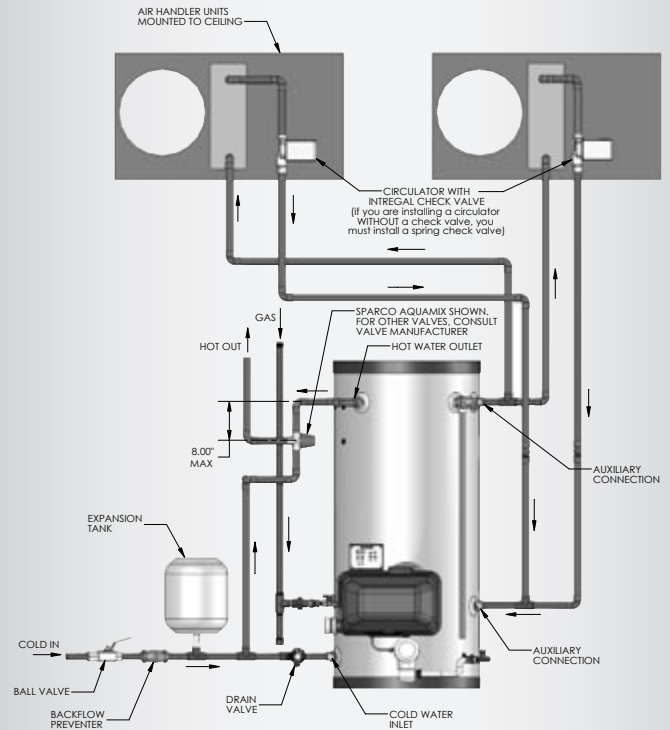

NOTES:

1. Minimum pipe size should match connection size on Phoenix. If you require greater flow upsize the pipe accordingly.
2. A Thermal Expansion tank suitable for potable water must be sized and installed within this piping system between the backflow preventer and the cold water inlet of the Phoenix.
3. Gas line must be rated to the maximum input capacity of the unit. Unit must have 10 feet of pipe after gas regulator.
4. Check with the manufacturer of the Air Handlers for proper sizing to the Phoenix.

PHOENIX SOLAR PIPING

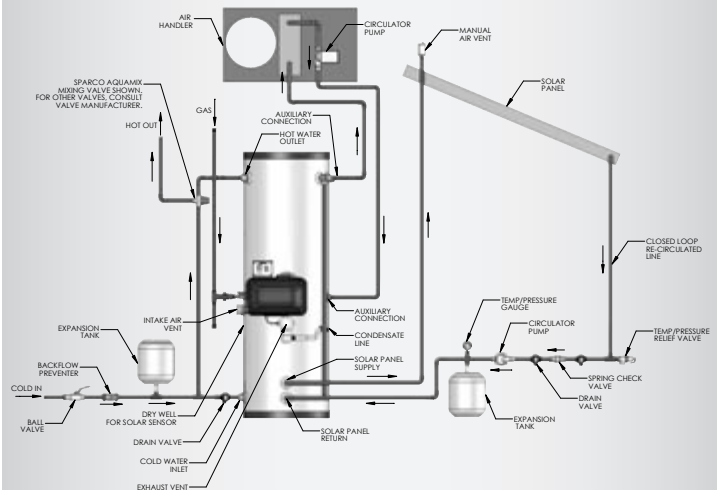

PHOENIX Recovery Capacities

Model	Input Modulation	40° rise	50° rise	60° rise	70° rise	80° rise	90° rise	100° rise	110° rise	120° rise	Gallon Capacity	First Hr Rating	Thermal %
PH199-119	66,000–199,000	575	460	383	329	287	256	230	209	192	119	335 Gallons	96.3%
PH130-119	44,000–130,000	379	303	253	217	190	168	152	138	126	119	257 Gallons	97.2%
PH100-119	44,000–100,000	293	235	196	168	147	130	117	107	98	119	214 Gallons	97.8%
PH199-80	66,000–199,000	573	458	382	327	286	255	229	208	191	80	314 Gallons	95.9%
PH130-80	44,000–130,000	376	301	251	215	188	167	150	137	125	80	227 Gallons	96.4%
PH100-80	44,000–100,000	291	233	194	166	145	129	116	106	97	80	189 Gallons	96.9%
PH199-55	66,000–199,000	573	458	382	327	286	254	229	208	191	55	295 Gallons	95.9%
PH130-55	44,000–130,000	370	296	247	211	185	164	148	134	123	55	205 Gallons	94.8%
PH100-55	44,000–100,000	288	230	192	165	144	128	115	105	96	55	169 Gallons	95.9%

Recovery ratings are based on thermal efficiencies per ANSI Z21.10.3-1998

PHOENIX Solar Recovery Capacities

Model	Gallon Capacity	Input BTU/hr	Heated Water Volume of Gas Back-Up at First Draw	Recovery Time	
				65° Rise	90° Rise
PH199-119S	119	66,000–199,000	61 GAL	10 MIN	14 MIN
PH199-80S	80	66,000–199,000	41 GAL	7 MIN	10 MIN
PH130-119S	119	44,000–130,000	61 GAL	16 MIN	21 MIN
PH130-80S	80	44,000–130,000	41 GAL	11 MIN	15 MIN

PHOENIX Specification

The Phoenix Water Heater shall be manufactured by Heat Transfer Products, Inc. with identification of model number PH_____. The water heater shall be a sealed combustion system, taking only outside air for combustion and exhausting the flue gas with PVC Schedule 40 or 80 PVC, or CPVC solid core pipe. The heater as well as all related intake air and exhaust intake air and exhaust gas piping shall be approved for zero clearance to any combustible surface. The units total combined equivalent venting length, including fitting allowances for both the intake air and exhaust gas shall not exceed 85' (in the units native size as manufactured and stated on the unit model product data sheet) in 2", or 3" pipe or 125' for the next size up of 3" or 4" from the heaters location.

The heaters tank shall be constructed of 316L stainless steel. The primary condensing heat exchanger shall be constructed of 90/10 cupronickel. The secondary heat exchanger shall be constructed of 800H stainless steel and 90/10 cupronickel. The tank insulation shall be water blown foam 2" thick in the side wall with a rating of R14.2 and 3" thick in the top with a rating of R21.3. Insulation shall be enclosed in a plastic jacket on the sides as well as the top and bottom. All components shall be located on the front of the heater for easy access and serviceability. All related hardware shall be constructed of stainless steel studs with brass

nuts for serviceability. All water connection nipples shall be constructed of stainless steel and be attached to the side of the tank. The top and bottom of the tank shall be smooth with no pipe tapings on the top or legs on the bottom.

Solar models shall have an additional heat exchanger on the bottom of the tank to connect to a solar system.

All heaters shall run at a combustion efficiency of 95% to 97% thermal efficiency. The heaters shall be UL/ULC listed and will exceed the minimum efficiency requirements of ASHRAE 90.1b -1992. All heaters shall be approved in accordance with ANSI Z 21.10.3. All heaters will be supplied with a factory installed ASME rated temperature and pressure relief valve. All heaters shall be supplied with a factory installed low water cutoff, and upper hot water sensor, and lower cold water sensor. All heaters shall be furnished with a factory installed condensate trap assembly ready for easy connection to a field supplied condensate drain.

The heater shall have an integrated digital controller device with integral diagnostics, LED fault and temperature settings for establishing set point, temperature differential. Ignition shall be with direct spark with ignition taking place at a pre-set ignition speed for the burner blower. The control shall utilize an algorithm to fully adjust the burner modulating firing rate while maintaining the desired temperature. The pre-mix stainless steel burner uses a 120 volt motor with pulse wave modulation control

to change the fan speed, thus the combustion air volume of fuel and air through the burner to establish and infinite BTU input range equal to the water heating set point requirement. The digital LED control display shall provide means, via push buttons, for adjustments of operating temperatures, differential adjustment, ECO reset, service mode, and real time status mode. In addition there shall be provided a computer connection via laptop computer for perpetual history including all fault codes, and hours of operation above 50% of input, below 50% of input as well as real time status reporting of all operations. The burner assembly shall be mounted so as to be easily removed as an integral unit for easy serviceability.

The heater shall be in compliance with the NOx Emissions limit as set forth in SCAQMD Rule 1146.2 – 1998.

The heater shall be factory assembled; test fired for correct BTU input and adjusted for proper combustion parameters. Complete operating and installation instructions shall be furnished with every heater as packaged by the manufacturer with the heater for shipping.

Heat Transfer
Advanced Heating and
Hot Water Systems